

ASSP Mobile Communication Systems

SAW DUAL FILTER (700 to 1700 MHz)

G5CH/G6CH Series (L2)

■ DESCRIPTION

The G5CH/G6CH series of SAW filters apply to the frequency range 700 to 1700 MHz.

The recent spread of handheld phone has resulted in size, cost reduction and lightweight needs. To meet such needs, Fujitsu has developed a SAW dual filter incorporating two SAW filters in one package.

Like conventional filters, the dual filters fabricated on a lithium tantalate (LiTaO_3) substrate with a large electromechanical coupling coefficient provide small package (3.8 mm sq), contributing to reduce mounting space and cost.

The SAW dual filter is available in two types, as combined two receiving filters (PDC800, GSM), and as combined receiving and local injection filter (AMPS, GSM etc.).

■ FEATURES

- Two functions are incorporated in one package
- Ultra compact and light package (3.8 mm sq, 0.02 cc, 0.1 g)
- 50 ohms of input/output impedance
- Surface mount package (SMT)
- Low insertion loss
- High handling power (0.2 W of guarantee)
- 2 in/2 out and 1 in/2 out (2 in/1 out) of package types are available

■ PACKAGE

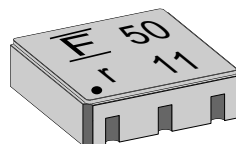

G5CH/G6CH series (L2)

■ PIN ASSIGNMENT

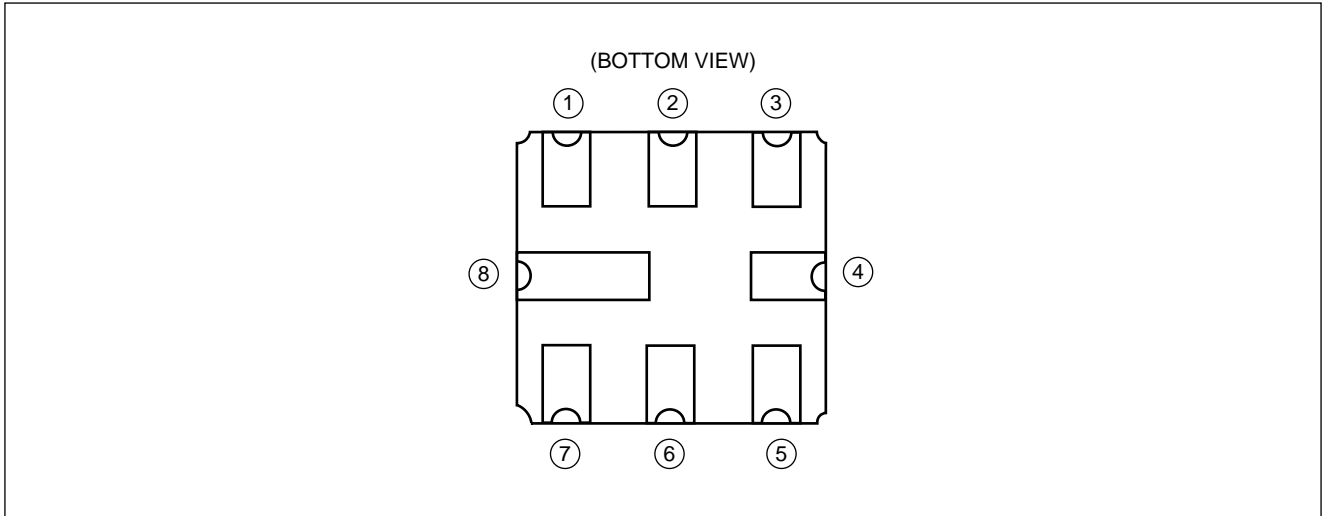

■ PIN DESCRIPTIONS

1. 2 in/2 out type

Pin No.	Pin name	Description
1	IN	Filter 1 input pin
2	GND	Ground pin
3	IN	Filter 2 input pin
4	GND	Ground pin
5	OUT	Filter 2 output pin
6	GND	Ground pin
7	OUT	Filter 1 output pin
8	GND	Ground pin

2. 1 in/2 out type

Pin No.	Pin name	Description
1	IN	Input pin (common)
2	GND	Ground pin
3	GND	Ground pin
4	GND	Ground pin
5	OUT	Filter 2 output pin
6	GND	Ground pin
7	OUT	Filter 1 output pin
8	GND	Ground pin

■ INTERNAL BLOCK DIAGRAM

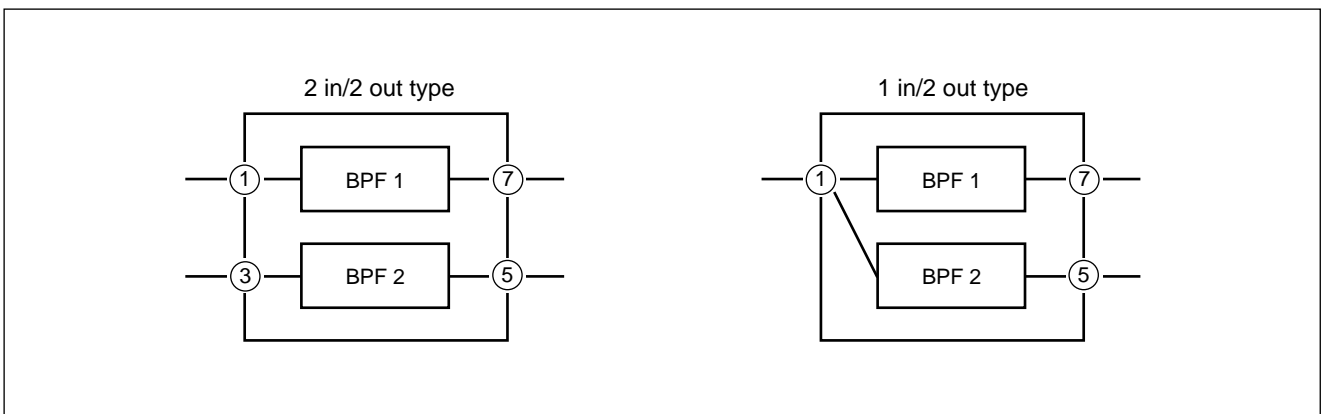

G5CH/G6CH series (L2)

■ ABSOLUTE MAXIMUM RATINGS (See WARNING)

Parameter	Symbol	Rating	Unit
Operating temperature	T _a	-30 to +85	°C
Storage temperature	T _{stg}	-40 to +100	°C
Maximum input power	P _{IN}	200	mW
Frequency range	—	700 to 1700	MHz

WARNING: Permanent device damage may occur if the above **Absolute Maximum Ratings** are exceeded. Functional operation should be restricted to the conditions as detailed in the operational sections of this data sheet. Exposure to absolute maximum rating conditions for extended periods may affect device reliability.

■ RECOMMENDED OPERATING CONDITIONS

Parameter	Symbol	Value	Unit
Operating temperature	T _a	-30 to +85	°C

■ STANDARD FREQUENCIES

No.	System	Frequency (MHz)	Input/Output	Part symbol	Part number	Remarks
1	Dual Band PDC800-Rx	810 to 828 MHz	2 in/ 2 out	06	FAR-G5CH-877M50-L206	
		870 to 885 MHz				
2	Dual Band PDC800-Rx	810 to 828 MHz	2 in/ 2 out	07	FAR-G5CH-877M50-L207	High attenuation type
		870 to 885 MHz				
3	Dual Band PDC800-Rx	810 to 828 MHz	1 in/ 2 out	50	FAR-G5CH-877M50-L250	High attenuation type
		870 to 885 MHz				
4	Dual Band PDC800-Rx	810 to 828 MHz	1 in/ 2 out	54	FAR-G5CH-877M50-L254	
		870 to 885 MHz				

Note: Dual filters shown below are also available.

- GSM Rx + Lo
- EGSM Rx + Lo
- AMPSx Rx + Lo
- ETACS Rx + Lo
- NTACS Rx + Lo

G5CH/G6CH series (L2)

■ ELECTRIC CHARACTERISTICS

1. Dual Band PDC800 (Rx) 2 in/2 out Part number: FAR-G5CH-877M50-L206

(T_a = -30 to +85°C)

Parameter	Symbol	Conditions	Value			Unit	Remarks	
			Min.	Typ.	Max.			
Filter 1	Insertion loss	IL	810 to 828 MHz	—	1.6	2.5	dB	
	Inband ripple	—	810 to 828 MHz	—	0.6	1.5	dB	
	Absolute attenuation	—	600 to 750 MHz	25	27	—	dB	
		—	750 to 780 MHz	30	38	—	dB	
		—	860 to 1200 MHz	25	34	—	dB	
Inband VSWR	—	810 to 828 MHz	—	1.3	2.0	—		
Filter 2	Insertion loss	IL	870 to 885 MHz	—	1.5	2.5	dB	
	Inband ripple	—	870 to 885 MHz	—	0.5	1.5	dB	
	Absolute attenuation	—	600 to 780 MHz	23	25	—	dB	
		—	780 to 830 MHz	25	31	—	dB	
		—	925 to 1200 MHz	25	31	—	dB	
Inband VSWR	—	870 to 885 MHz	—	1.4	2.0	—		

2. Dual Band PDC800 (Rx) 2 in/2 out High Attenuation type Part number: FAR-G5CH-877M50-L207

(T_a = -30 to +85°C)

Parameter	Symbol	Conditions	Value			Unit	Remarks	
			Min.	Typ.	Max.			
Filter 1	Insertion loss	IL	810 to 828 MHz	—	2.0	3.5	dB	
	Inband ripple	—	810 to 828 MHz	—	0.5	2.0	dB	
	Absolute attenuation	—	600 to 700 MHz	35	41	—	dB	
		—	720 to 780 MHz	30	40	—	dB	
		—	860 to 960 MHz	30	40	—	dB	
		—	960 to 1200 MHz	25	35	—	dB	
Inband VSWR	—	810 to 828 MHz	—	1.7	2.5	—		
Filter 2	Insertion loss	IL	870 to 885 MHz	—	2.2	3.5	dB	
	Inband ripple	—	870 to 885 MHz	—	1.7	2.0	dB	
	Absolute attenuation	—	600 to 760 MHz	35	37	—	dB	
		—	760 to 830 MHz	35	42	—	dB	
		—	925 to 1000 MHz	35	43	—	dB	
		—	1000 to 1200 MHz	30	40	—	dB	
Inband VSWR	—	870 to 885 MHz	—	1.3	2.5	—		

G5CH/G6CH series (L2)

3. Dual Band PDC800 (Rx) 1 in/2 out High Attenuation type Part number: FAR-G5CH-877M50-L250

(T_a = -30 to +85°C)

Parameter	Symbol	Conditions	Value			Unit	Remarks	
			Min.	Typ.	Max.			
Filter 1	Insertion loss	IL	810 to 828 MHz	—	2.7	3.5	dB	
	Inband ripple	—	810 to 828 MHz	—	0.7	1.5	dB	
	Absolute attenuation	—	600 to 750 MHz	30	33	—	dB	
		—	750 to 780 MHz	20	38	—	dB	
		—	870 to 925 MHz	25	34	—	dB	
		—	925 to 1000 MHz	35	40	—	dB	
	—	1000 to 1200 MHz	40	43	—	dB		
Inband VSWR	—	810 to 828 MHz	—	2.2	3.0	—		
Filter 2	Insertion loss	IL	870 to 885 MHz	—	2.8	3.5	dB	
	Inband ripple	—	870 to 885 MHz	—	0.8	1.5	dB	
	Absolute attenuation	—	600 to 780 MHz	30	37	—	dB	
		—	780 to 828 MHz	20	38	—	dB	
		—	925 to 1000 MHz	35	45	—	dB	
		—	1000 to 1200 MHz	40	47	—	dB	
Inband VSWR	—	870 to 885 MHz	—	1.6	3.0	—		

4. Dual Band PDC800 (Rx) 1 in/2 out Part number: FAR-G5CH-877M50-L254

(T_a = -30 to +85°C)

Parameter	Symbol	Conditions	Value			Unit	Remarks	
			Min.	Typ.	Max.			
Filter 1	Insertion loss	IL	810 to 828 MHz	—	2.0	3.0	dB	
	Inband ripple	—	810 to 828 MHz	—	0.5	1.5	dB	
	Absolute attenuation	—	600 to 750 MHz	25	27	—	dB	
		—	750 to 780 MHz	15	18	—	dB	
		—	870 to 960 MHz	25	33	—	dB	
		—	960 to 1000 MHz	20	26	—	dB	
	—	1000 to 1200 MHz	18	25	—	dB		
Inband VSWR	—	810 to 828 MHz	—	2.3	3.0	—		
Filter 2	Insertion loss	IL	870 to 885 MHz	—	2.5	3.0	dB	
	Inband ripple	—	870 to 885 MHz	—	1.0	1.5	dB	
	Absolute attenuation	—	600 to 780 MHz	30	35	—	dB	
		—	780 to 828 MHz	20	30	—	dB	
		—	925 to 1000 MHz	28	33	—	dB	
		—	1000 to 1200 MHz	20	30	—	dB	
Inband VSWR	—	870 to 885 MHz	—	1.9	3.0	—		

G5CH/G6CH series (L2)

■ TYPICAL CHARACTERISTICS (STANDARD VERSION)

1. Dual Band PDC800 (Rx) 2 in/2 out Part number: FAR-G5CH-877M50-L206

Filter 1: Frequency band 810 MHz to 828 MHz

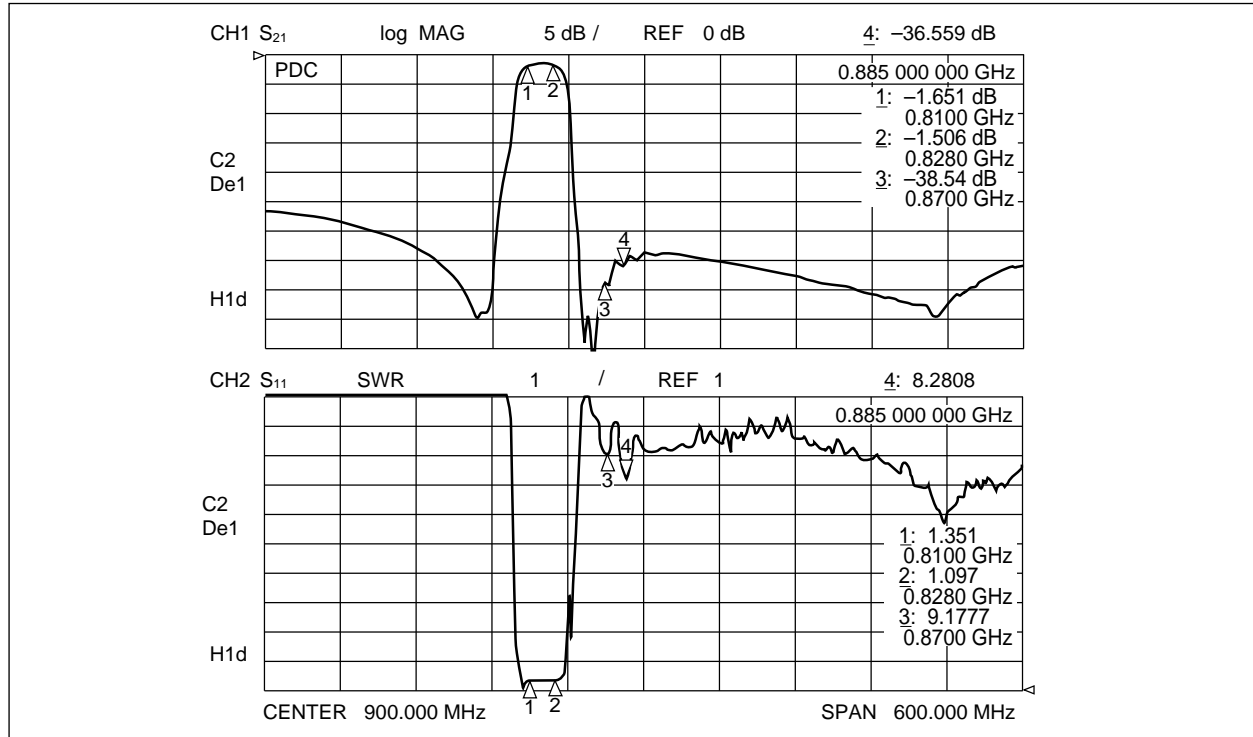

Filter 2: Frequency band 870 MHz to 885 MHz

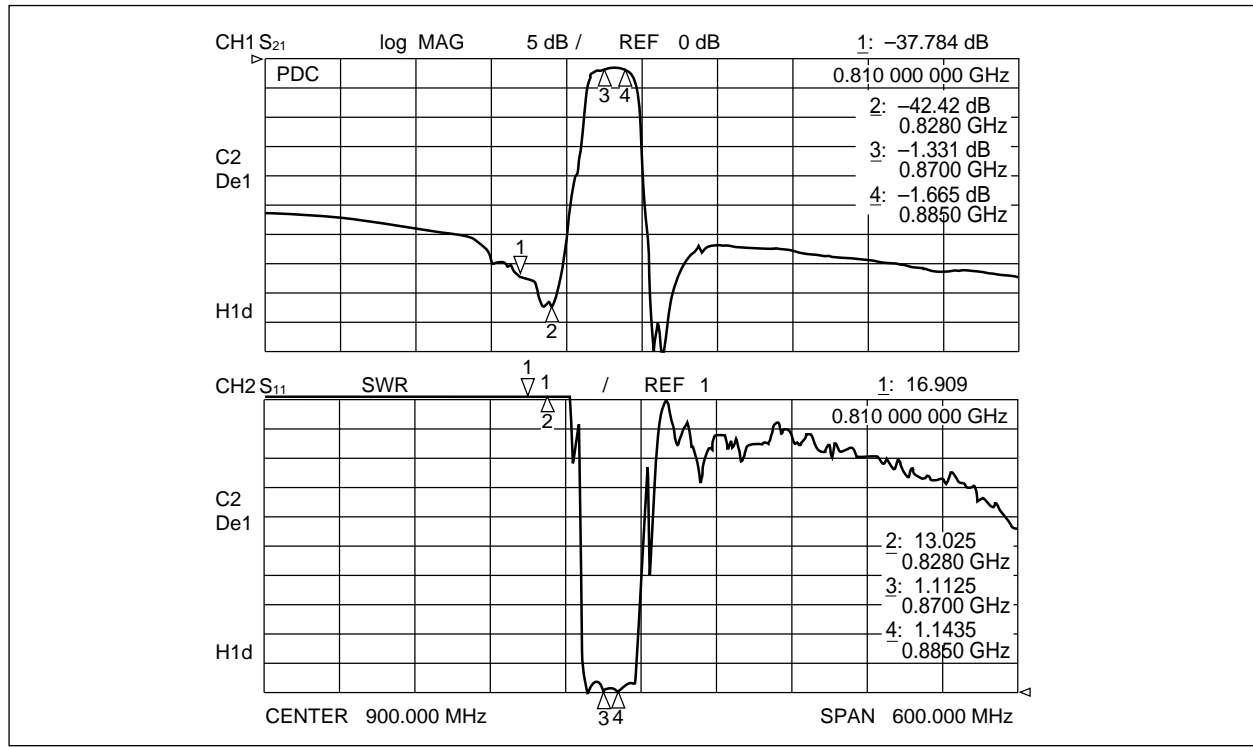

G5CH/G6CH series (L2)

2. Dual Band PDC800 (Rx) 2 in/2 out High Attenuation type Part number: FAR-G5CH-877M50-L207

Filter 1: Frequency band 810 MHz to 828 MHz

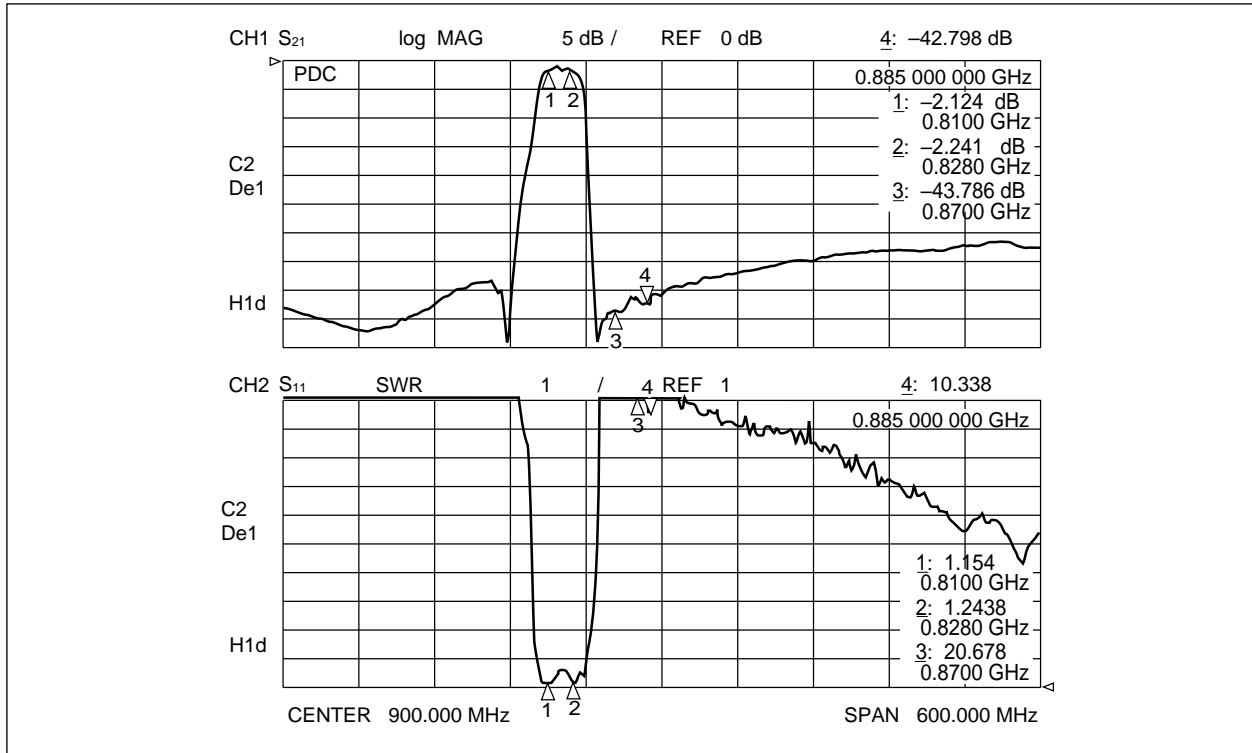

Filter 2: Frequency band 870 MHz to 885 MHz

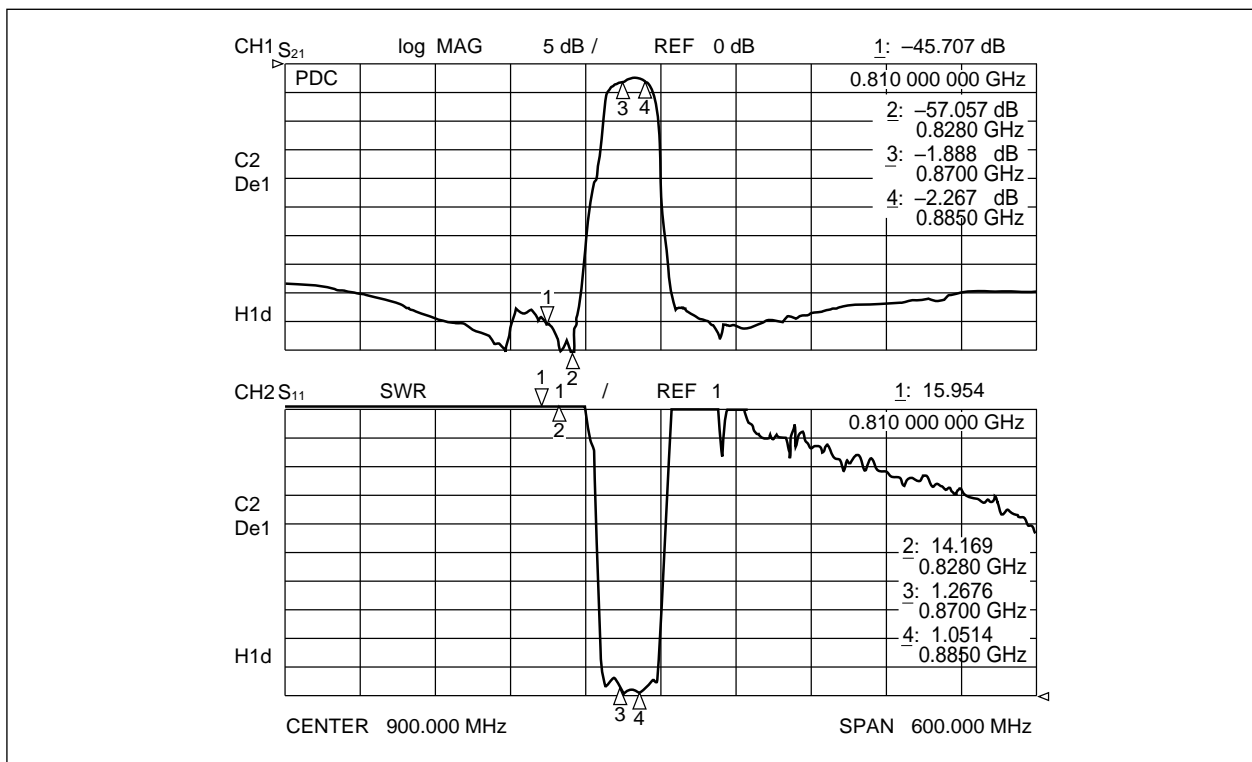

G5CH/G6CH series (L2)

3. Dual Band PDC800 (Rx) 1 in/2 out High Attenuation type Part number: FAR-G5CH-877M50-L250

Filter 1: Frequency band 810 MHz to 828 MHz

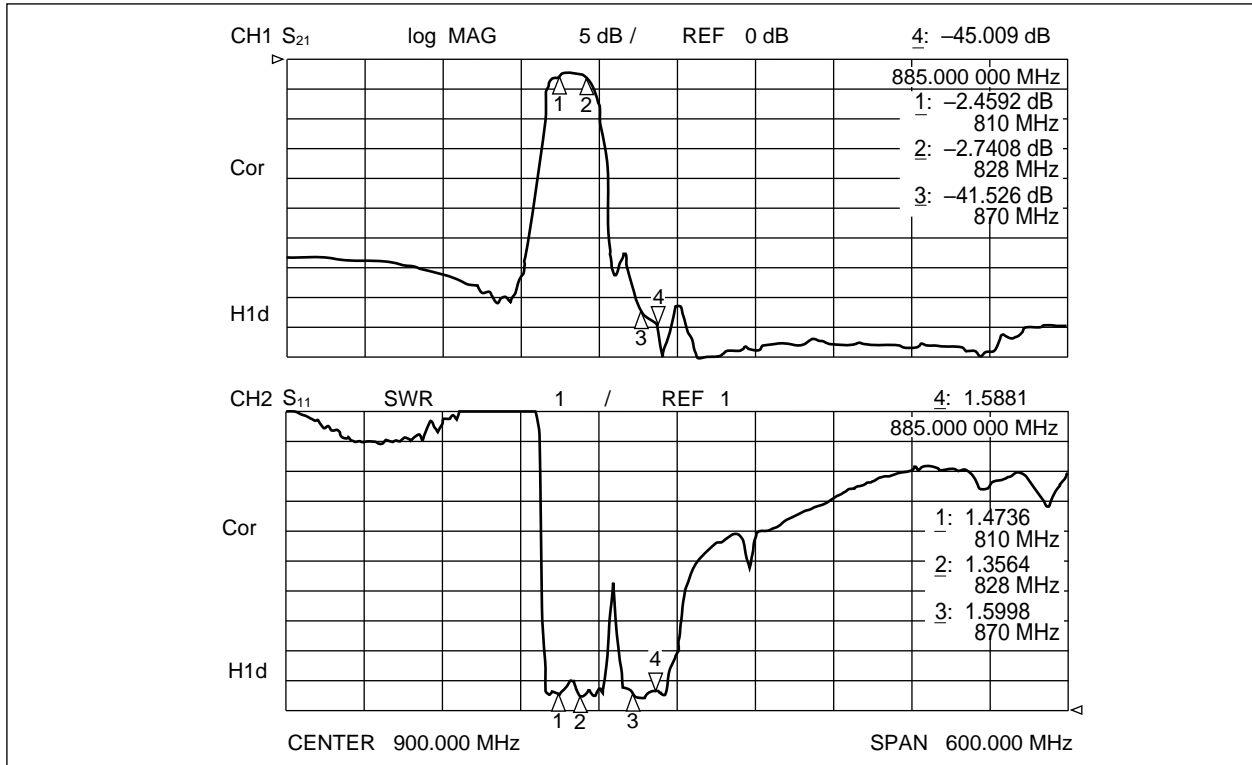

Filter 2: Frequency band 870 MHz to 885 MHz

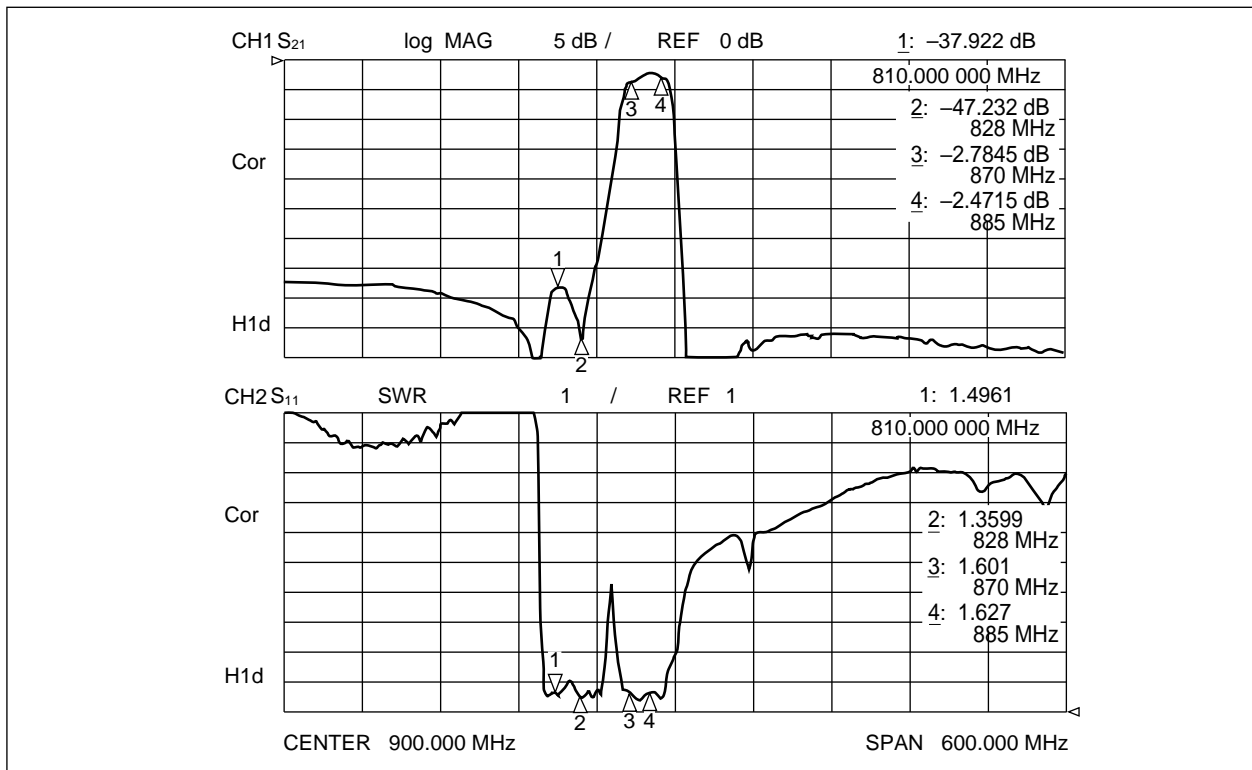

G5CH/G6CH series (L2)

4. Dual Band PDC800 (Rx) 1 in/2 out Part number: FAR-G5CH-877M50-L254

Filter 1: Frequency band 810 MHz to 828 MHz

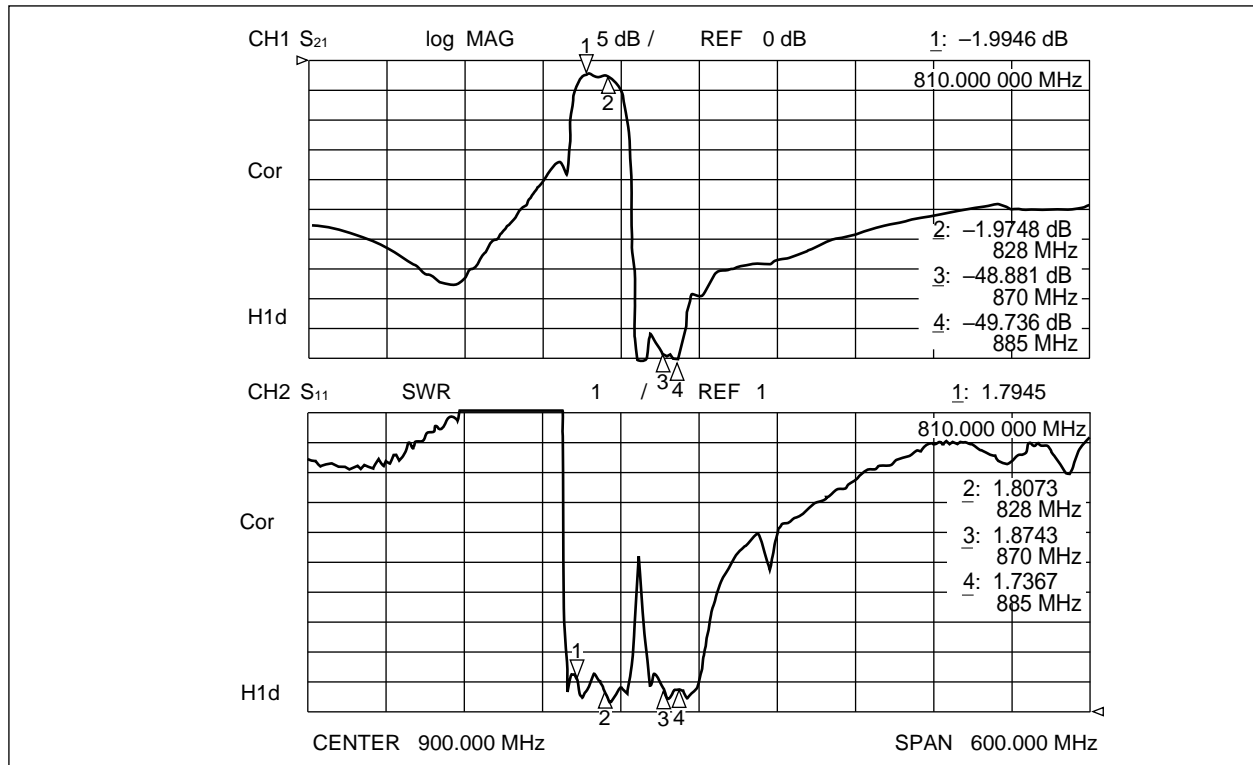

Filter 2: Frequency band 870 MHz to 885 MHz

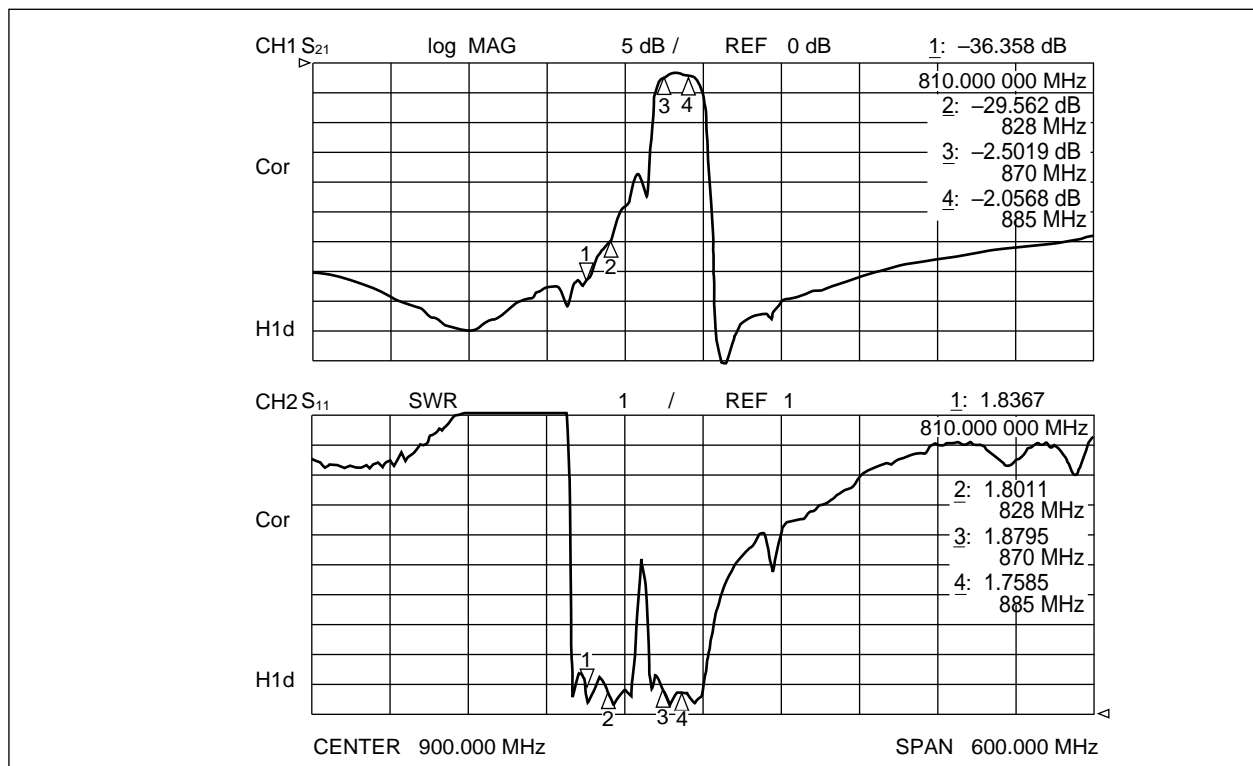

G5CH/G6CH series (L2)

MEASUREMENT CIRCUIT

1. 2 in/2 out type

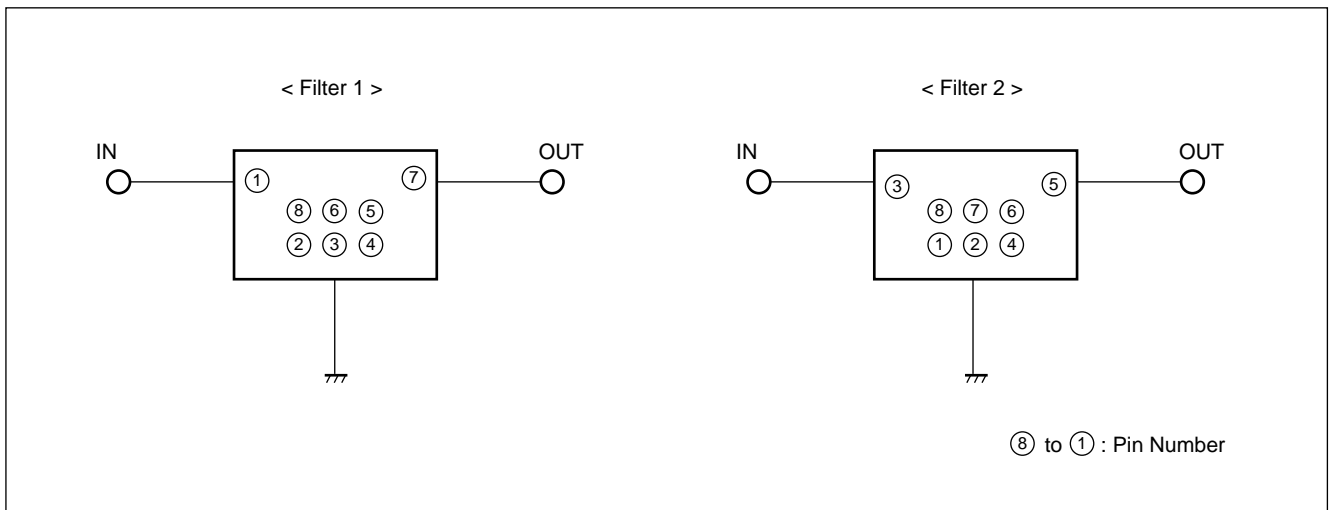

2. 1 in/2 out type

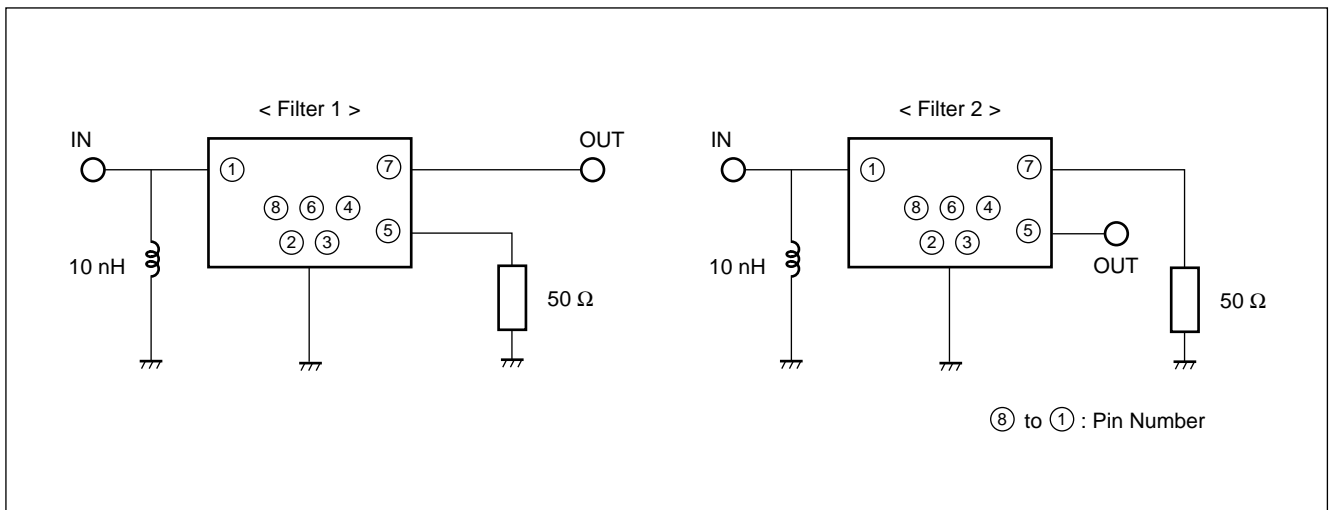

RECOMMENDED EXTERNAL CIRCUIT OF 1 IN/2 OUT TYPE

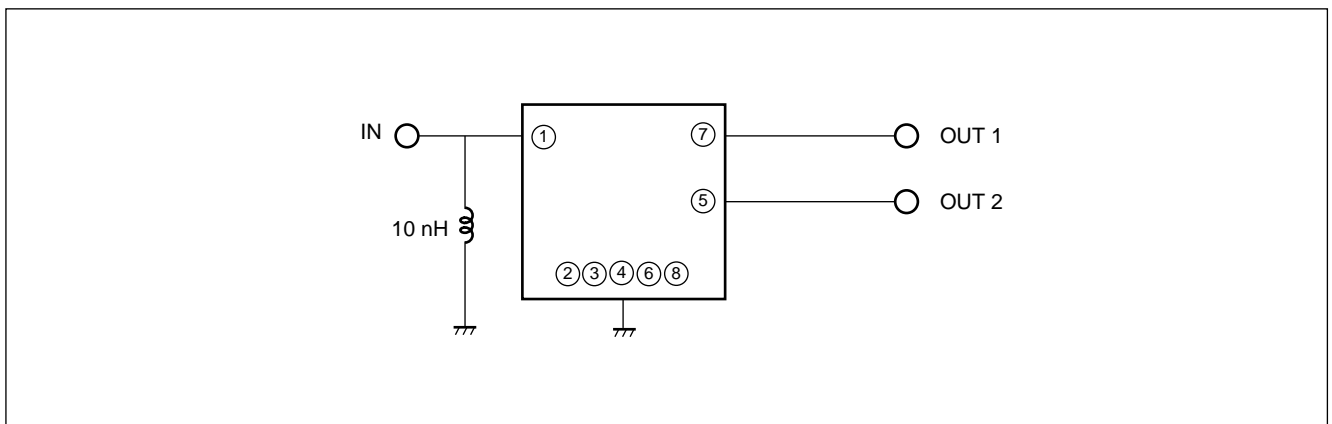

G5CH/G6CH series (L2)

MARKING

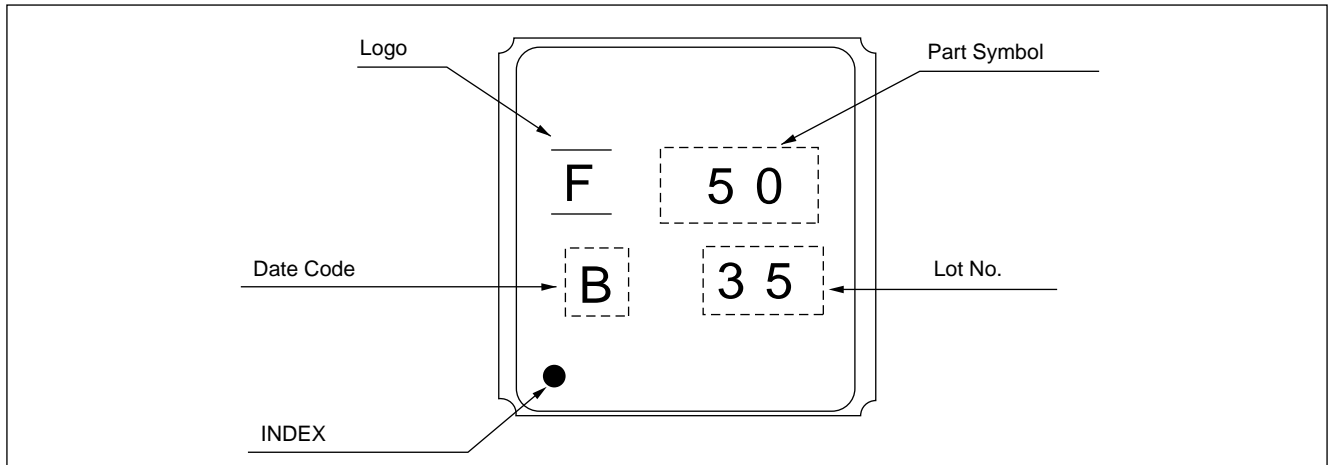

PART NUMBER DESIGNATION

[Designation example]

FAR-G□ 5CH-□□□□□□-L2 □□-□
 (1) (2) (3) (4)

- (1) Frequency range: 5: 700 to 1000 MHz
 6: 1000 to 1700 MHz

(2) Frequency: Specify the nominal center frequency of higher frequency side in six alphanumeric. Enter M (for MHz) at the decimal point. Refer to below example.
 Example: 877.5 MHz ⇒ 877M50

(3) Part symbol: Specified characters from 01 to 99.

(4) Packing: T: 1 k pcs/reel
 R: 3 k pcs/reel

PACKAGE DIMENSION

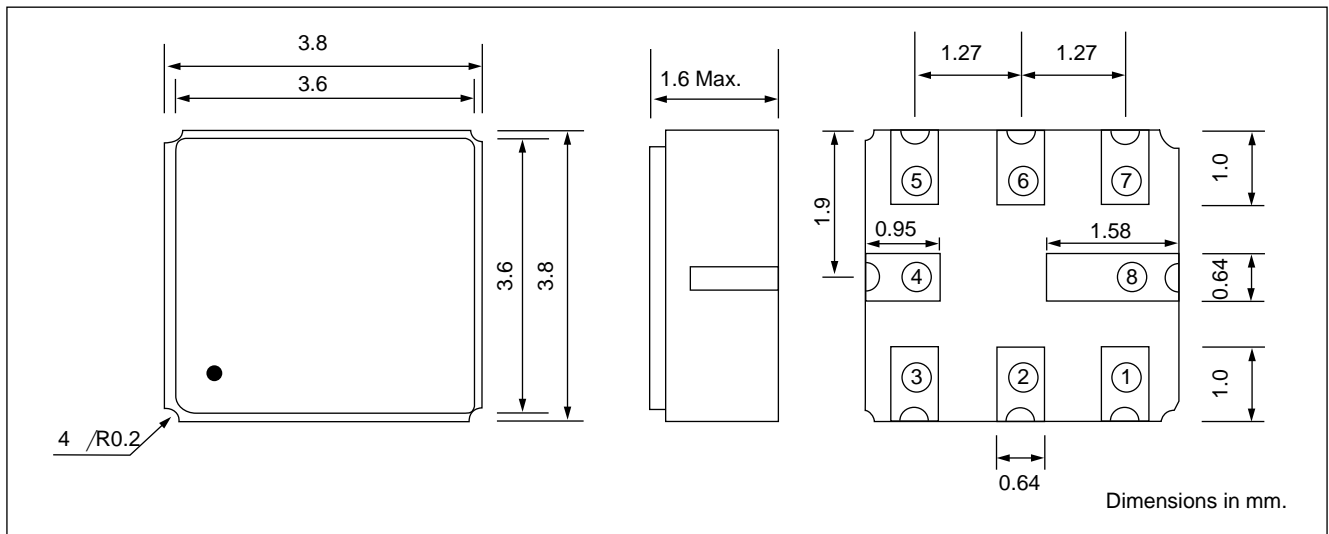

G5CH/G6CH series (L2)

■ PACKING: Reel type

1. Reel dimensions

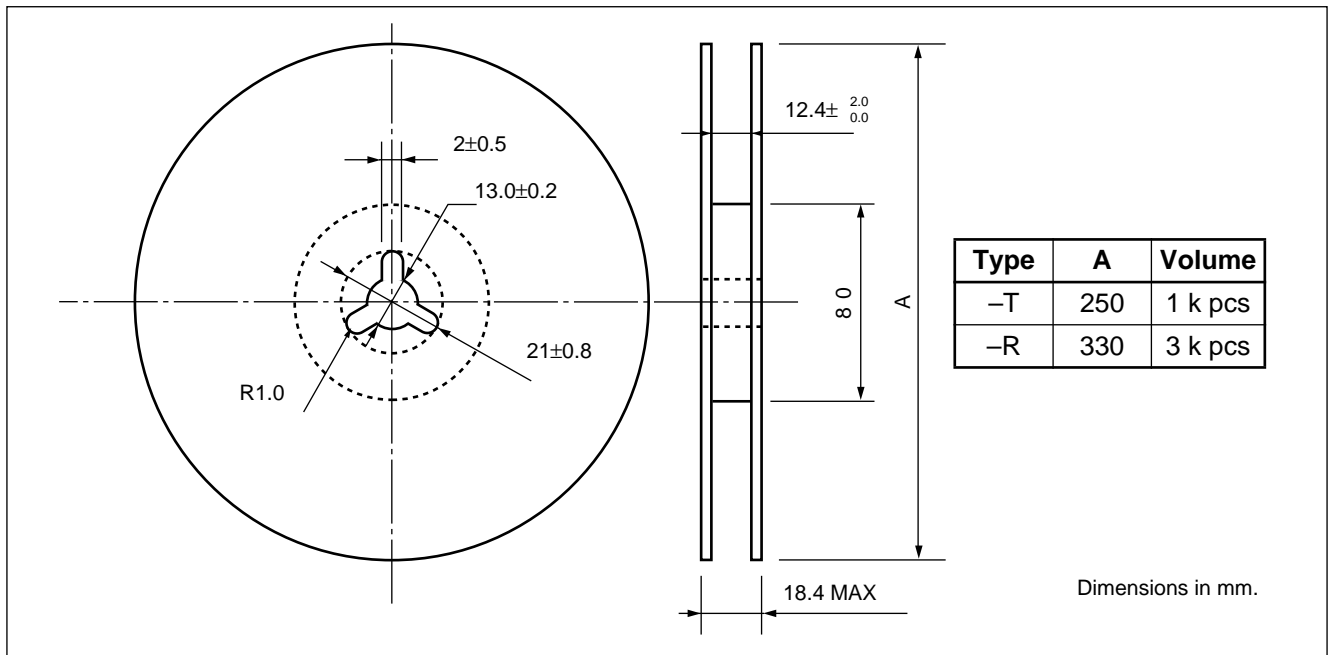

2. Packing style

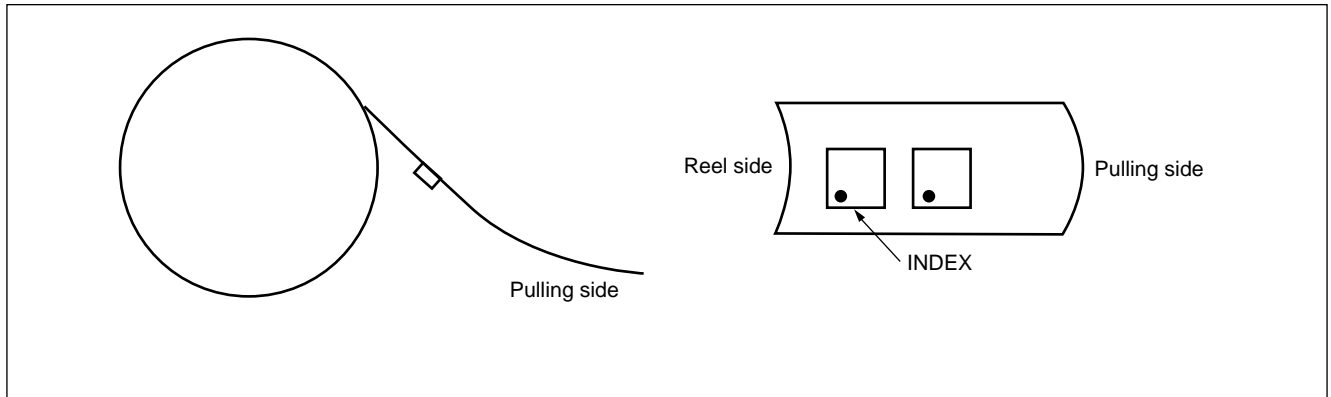

3. Tape dimensions

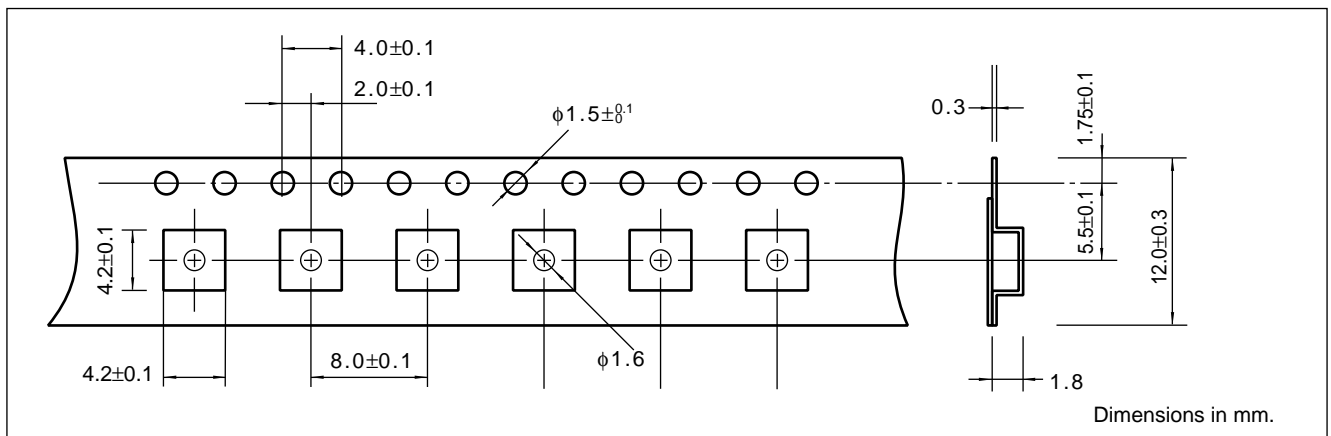

FUJITSU LIMITED

For further information please contact:

Japan

FUJITSU LIMITED
Corporate Global Business Support Division
Electronic Devices
KAWASAKI PLANT, 4-1-1, Kamikodanaka
Nakahara-ku, Kawasaki-shi
Kanagawa 211-88, Japan
Tel: (044) 754-3763
Fax: (044) 754-3329

North and South America

FUJITSU MICROELECTRONICS, INC.
Semiconductor Division
3545 North First Street
San Jose, CA 95134-1804, U.S.A.
Tel: (408) 922-9000
Fax: (408) 432-9044/9045

Europe

FUJITSU MIKROELEKTRONIK GmbH
Am Siebenstein 6-10
63303 Dreieich-Buchsschlag
Germany
Tel: (06103) 690-0
Fax: (06103) 690-122

Asia Pacific

FUJITSU MICROELECTRONICS ASIA PTE. LIMITED
#05-08, 151 Lorong Chuan
New Tech Park
Singapore 556741
Tel: (65) 281-0770
Fax: (65) 281-0220

All Rights Reserved.

The contents of this document are subject to change without notice. Customers are advised to consult with FUJITSU sales representatives before ordering.

The information and circuit diagrams in this document presented as examples of semiconductor device applications, and are not intended to be incorporated in devices for actual use. Also, FUJITSU is unable to assume responsibility for infringement of any patent rights or other rights of third parties arising from the use of this information or circuit diagrams.

FUJITSU semiconductor devices are intended for use in standard applications (computers, office automation and other office equipment, industrial, communications, and measurement equipment, personal or household devices, etc.).

CAUTION:

Customers considering the use of our products in special applications where failure or abnormal operation may directly affect human lives or cause physical injury or property damage, or where extremely high levels of reliability are demanded (such as aerospace systems, atomic energy controls, sea floor repeaters, vehicle operating controls, medical devices for life support, etc.) are requested to consult with FUJITSU sales representatives before such use. The company will not be responsible for damages arising from such use without prior approval.

Any semiconductor devices have inherently a certain rate of failure. You must protect against injury, damage or loss from such failures by incorporating safety design measures into your facility and equipment such as redundancy, fire protection, and prevention of over-current levels and other abnormal operating conditions.

If any products described in this document represent goods or technologies subject to certain restrictions on export under the Foreign Exchange and Foreign Trade Control Law of Japan, the prior authorization by Japanese government should be required for export of those products from Japan.